



WATER-COOLED HEAT EXCHANGERS

Cooling for Hydrocarbon Gas & Vapor Streams

HEX Cooler Features:

- Water-cooled exchanger for use in controlling gas temperature during processing
- Key components: plated heat exchanger and water separator with drain
- Tailored specifically for EcoVapor's catalytic O₂ removal units ("ZerO2")
- Ease of service
- Choice of instrumentation available



	HC650	HC1250	HC1900	HC2850
NOMINAL FLOW RATE	100 - 650 MSCFD	500 – 1,250 MSCFD	900 – 1,900 MSCFD	1,500 – 2,850 MSCFD
MAWP	232 psi @ 250 °F	232 psi @ 250 °F	232 psi @ 250 °F	232 psi @ 250 °F
PROCESS CONNECTION	2" 150#	2" 150#	2" 150#	3" 150#
MAX Cooling Required	5 TONS	7.5 TONS	10 TONS	15 TONS

Each model has the option for standard instrumentation ("L" models, for example, HC650L) and additional instrumentation ("H" models, HC650H)

Standard Instrumentation ("L" models)	Additional Instrumentation ("H" models)
Discharge temperature transmitter	Inlet temperature transmitter on process line
Water separator & automatic drain	Inlet temperature gauge on process & cooling lines
Liquids drain line	Discharge pressure transmitter on process line
Isolation butterfly valves on both process and coolant lines	Discharge temperature gauge on process & cooling lines

	HC650L	HC1250L	HC1900L	HC2850L
APPROXIMATE WEIGHT (add 50 lbs for "H" models)	860 lbs	905 lbs	950 lbs	1,600 lbs
A	36"	36"	36"	42"
B	72"	72"	72"	72"
C	74"	74"	74"	76"
D	70.5"	70.5"	70.5"	88.5"
E	34.5"	34.5"	34.5"	40.5"
F	2.875"	2.875"	2.875"	3.0"
G	3.5"	3.5"	3.5"	3.5"
H	7.75"	7.75"	7.75"	8.0"
J	19.5"	19.5"	19.5"	24.5"
K	20.5"	20.5"	20.5"	24.5"
L	40"	40"	40"	40"
M	13.75"	13.75"	13.75"	14"
N	6.75"	6.75"	6.75"	6.75"



Corporate Office

1442 Delgany St. Suite 100
Denver, CO 80202

Field Offices

1804 Cherry Ave.
Greeley, CO 80631

915 Goode St.
Midland, TX 79701

5072 Owan Industrial Park Dr.
Williston, ND 58801

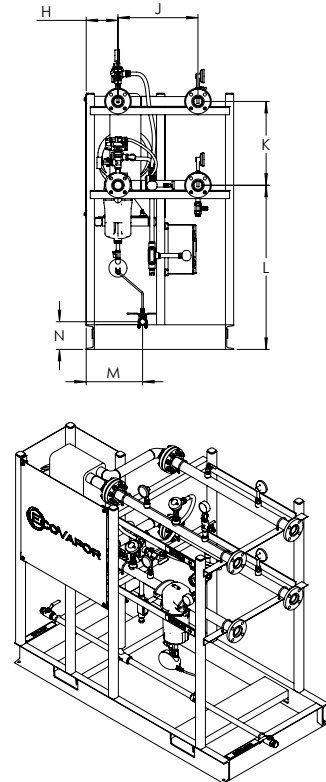
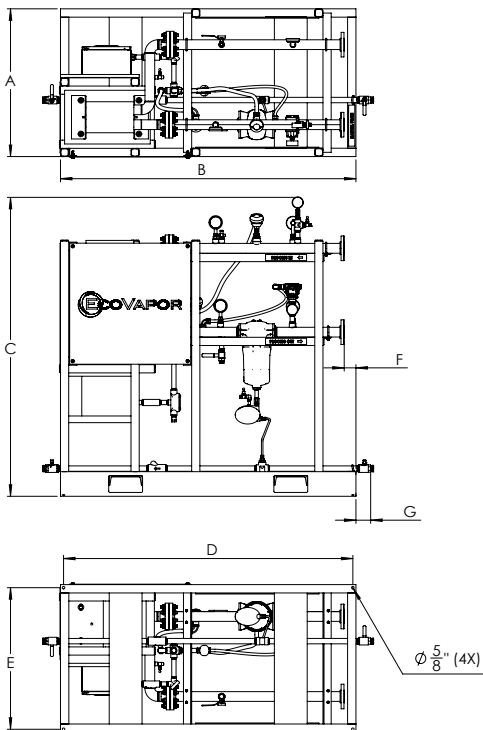

info@EcoVaporRS.com

1-844-No-Flare
(844.663.5273)