



EMISSIONS SCOUT - SITE ASSESSMENT

Evaluate Your Site's Flaring!

If you don't measure it, you can't manage it.

EcoVapor's Emissions Scout™ is the solution to fully understanding the emissions profile of your tank batteries. It quantifies actual volumes and sources of emissions.

About the Site Assessment:

- Easily assess flared volumes, tank pressure, and oxygen levels associated with storage tank vapor
- Fast installation, solar powered, no power connections required
- 24-hour remote system monitoring

Specifications

Dimensions 58" w, 53" d, 104" h

Approximate Weight: 2,100 lbs

Skid Hazard Classification: C1D2

Thermal Mass Meter Included:

- 1" threadolet required on-site for mounting
- Suitable for pipe sizes 2" to 6"
- Gas Temperature Ranges: -40°F to 140°F
- Class I, Div I, Groups B,C,D

Pressure Transmitter Included:

- Placement on tanks custom per site, provided by EcoVapor
- Wireless, 900 MHz Frequency
- Class I, Div 1, Groups A, B, C & D, T3

Oxygen Analyzer:

- Measure trace amounts of oxygen down to 1 ppm
- Class 1, Div 2, Groups, C, D
- Pump included to sample vapor pressures < 1 psi

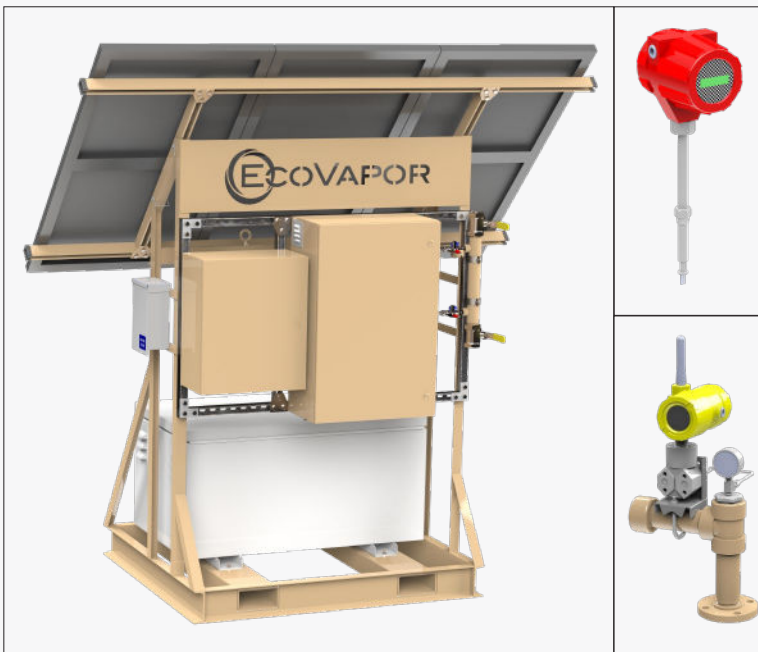

EMISSIONS SCOUT - SITE ASSESSMENT

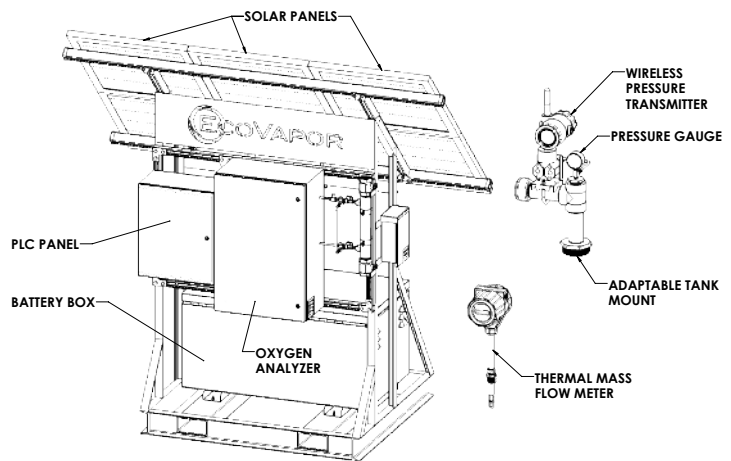
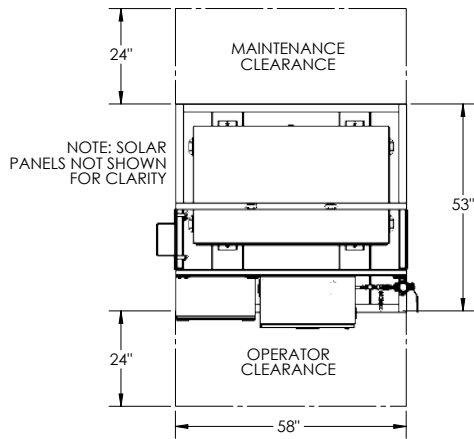
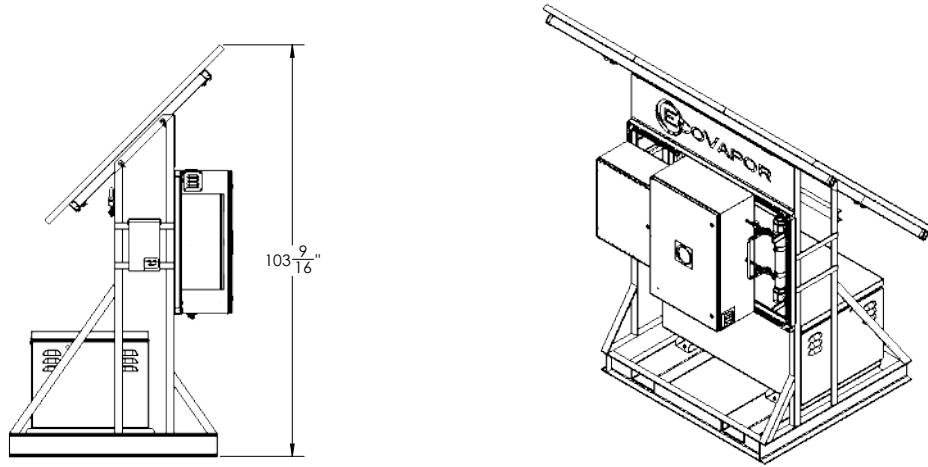

Site Layout

